



COMPACTION ROLLERS

**ROLL
WITH IT**



WORKS FOR YOU.™

SMOOTHLY DOES IT

Get on a roll with Terex® Compaction

With over 35 years of design and manufacturing expertise, we've come to know what you expect from your compaction equipment. That's why you'll find that the Terex compaction range is rental tough, reliable, easy to operate, and above all, productive.

Built with heavy duty fabrications and components to withstand the most demanding operators, they deliver outstanding compaction performance. Operators enjoy easy to use controls with an intuitive layout whilst vibration reducing technology enhances comfort and productivity.

From the small and versatile Terex MBR-71 pedestrian roller to the large and productive Terex TV1400 tandem vibratory roller, we've included features such as fully machined drums that provide an excellent surface finish, flush oil tube routing to prevent damage when compacting next to an obstacle and vandal proof instrumentation.

With the wide range of options available, heavy duty fabrications and components and high compaction performance, whatever your compaction needs are, Terex has it covered.

Fixed or folding ROPS

Sliding seat for operator comfort (additional lateral movement on TV1200H to TV1400 to provide improved drum visibility) all with safety cut-out switch

Easily selectable 1 or 2 drum vibration

Maintenance free (sealed for life) vibration bearings



COMPACTION ROLLERS

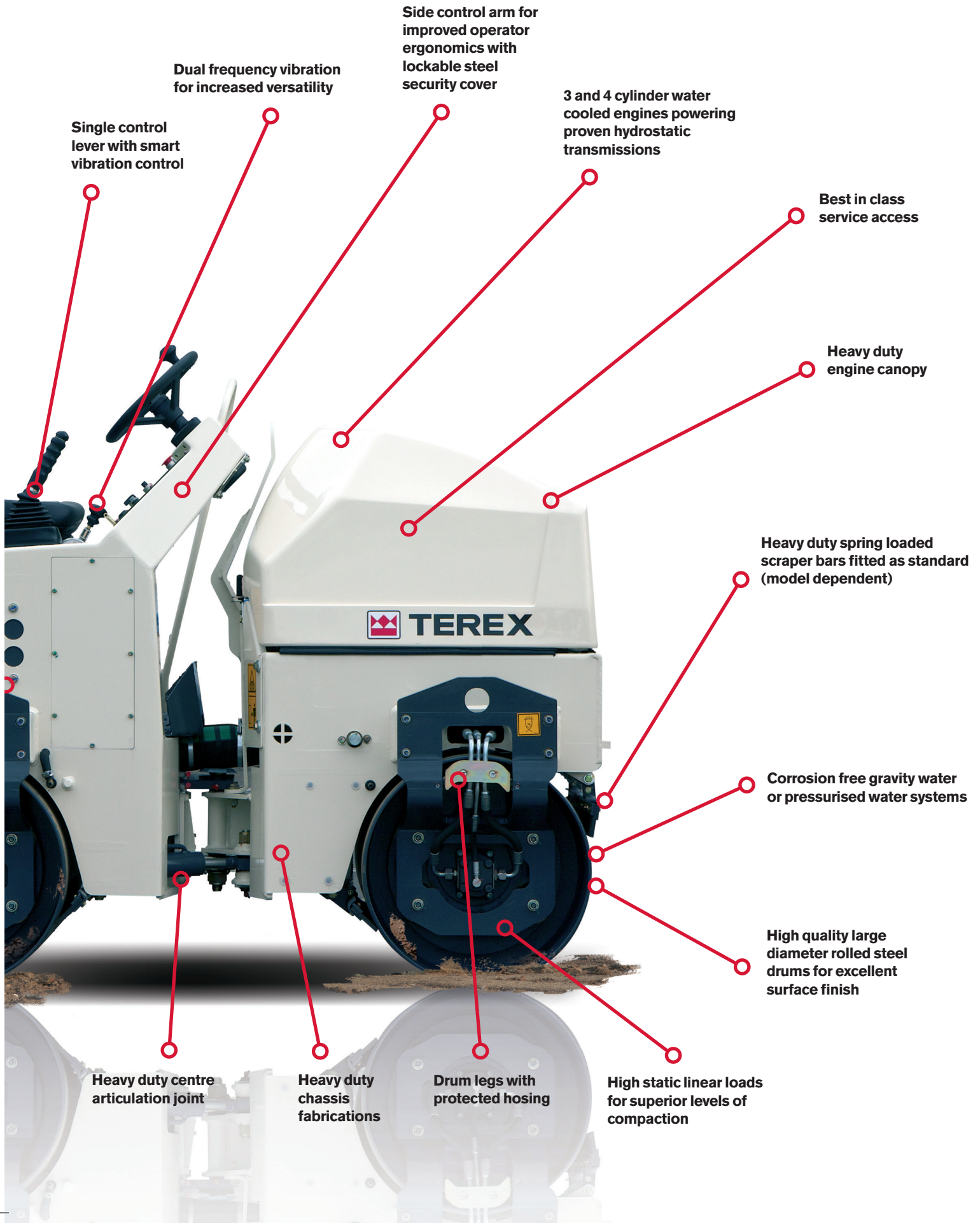

Single control lever with smart vibration control

Dual frequency vibration for increased versatility

Side control arm for improved operator ergonomics with lockable steel security cover

3 and 4 cylinder water cooled engines powering proven hydrostatic transmissions

Best in class service access

Heavy duty engine canopy

Heavy duty spring loaded scraper bars fitted as standard (model dependent)

Corrosion free gravity water or pressurised water systems

High quality large diameter rolled steel drums for excellent surface finish

Heavy duty centre articulation joint

Heavy duty chassis fabrications

Drum legs with protected hosing

High static linear loads for superior levels of compaction

MAKE A BIG IMPACT

Tandem Drum Rollers

Arguably some of the toughest in the world, the Terex range of compact Tandem Rollers are designed for the rigorous demands of the Plant Hire industry.

Meeting world-wide compaction standards for asphalt and granular layers, these machines not only provide 'rental toughness' they are operator friendly, high productivity rollers.

High compaction productivity is achieved via the powerful, well proven mass exciter system to deliver high dynamic force. Optimised balance between frequency and amplitude provides ultimate versatility in meeting all kinds of job site conditions.

The hydrostatic power management provides excellent hill climbing ability and when combined with the superb articulation delivering a tight turning circle, these are highly manoeuvrable machines.

Twin drum vibration or rear drum vibration is easily selectable at the turn of a lever. This makes small asphalt patching easier and reduces the risk of damage to the surrounding surfaces.

Featuring a unique steering arm offering the best legroom available on the market, high comfort seat, easy to read display and ergonomic controls, a Terex Compact Tandem Roller is comfortable and simple to operate.

A hydraulic breaker outlet is available on the TV800, TV800H and TV900 removing the need for a separate hydraulic powerpack or air compressor. The 12.7 mm quick release couplers provide a high 30 litre/minute flow rate (category 2) to the optional Terex breaker.

What this means for you

- ▶ Rugged 'rental tough' design to withstand plant hire industry conditions
- ▶ Water cooled diesel engines provide excellent reliability, low noise and low emissions
- ▶ High static linear loads reduce the number of passes
- ▶ 2 frequencies provide enhanced versatility
- ▶ Optional pressure fed water sprinkler provides greater flow regulation for improved cleaning capability



FOLLOW THE LEADER

Pedestrian Roller

Designed for the compaction of granular and asphalt materials, Terex Pedestrian rollers provide class leading performance in applications including highway repair, footpaths, cycle lanes, playgrounds and landscaping environments.

The proven design provides superb balance, making it easy to manoeuvre in tight spaces. The MBR-71 is fitted with a front prop and jockey wheel to help support the machine when not in use. A freewheel system is fitted as standard so that if the machine stops working, you can still move it easily.

Rubber couplings in the drum reduce vibration transfer for low hand-arm (HAV) levels for additional comfort. The drum is driven by a duplex chain and heavy duty reduction gear for extra strength.

The Terex MBR-71 is fitted with a 'hold to run' handle so that the hydraulic drive cuts off if the control lever is released. A transmission parking brake is also fitted for additional safety and security when the roller is not in use.

Break out – roll over

For added versatility the Terex MBR-71 roller features a high quality tow-behind trailer and hydraulic breaker combination. The hydraulic breaker is ideally suited to asphalt repair work for breaking out damaged materials prior to resurfacing.

What this means for you

- ▶ Reliable air cooled engine with electrical start for easy start up
- ▶ Effective drum clearing from front and rear scraper bars
- ▶ High capacity corrosion free water system ensures drum cleanliness at all times
- ▶ Hydrostatic transmission for easy manoeuvrability
- ▶ High quality surface finish on drum for improved results on asphalt surfaces



SPECIFICATIONS PEDESTRIAN ROLLER

PERFORMANCE

	MBR71
Total Static Basic Weight (kg)	504
Operating Weight (kg) CECE	513
Static Linear Load (kg/cm)	7.2
Frequency - Hz (VPM)	65 (3900)
Amplitude (mm)	0.66
Centrifugal Force (kN)	9.0
Gradeability - Without Vibration	33 %
Gradeability - With Vibration	25 %

ENGINE & DRIVE

	MBR71
Engine Make	Hatz
Engine Model	1D42S
Cylinders	1
Displacement (cc)	445.7
Cooling	Air
Power - kW (HP) (DIN ISO 1585)	6.6 (8.85)
Operating Speed (rpm)	3000
Fuel Type	Diesel
Drive	Hydrostatic via Duplex Chain
Maximum Travel Speed (kph) - Forwards	3.2
Maximum Travel Speed (kph) - Reverse	1.0
Braking System - Service	Dynamic Hydrostatic
Braking System - Parking	Spring Apply / Hydraulic Release (Over Centre)
Start Type	Electric

CAPACITIES

	MBR71
Hydraulic Tank Capacity (litres)	7.5
Fuel Tank Capacity (litres)	5
Water Tank Capacity (litres)	20

EMISSIONS

	MBR71
Noise (dB) - LwA (2000/14/EC / ISO 4871)	92.0dB
Engine Emissions	EPA IV / Euro Stage IIIA
Hand Arm Vibration (HAV) - (EN500-4)	3.6m/s ²

EXCITER

	MBR71
Type	Single Shaft
Drive	Vee Belt / Dry Clutch

WATER SPRAY SYSTEM

	MBR71
System Type	Gravity Fed with Non-Corrosive Spray Bar

DRUM SCRAPER BARS

	MBR71
System Type	Heavy Duty Adjustable - Front and Rear

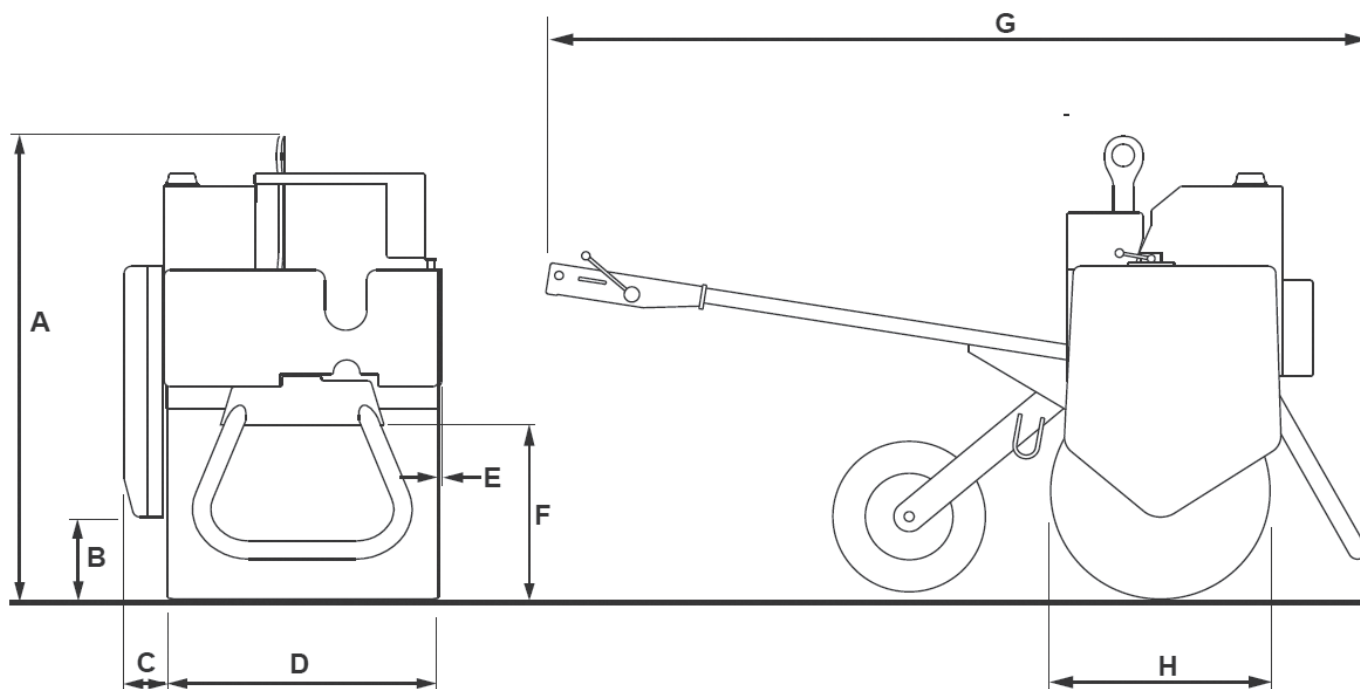

DIMENSIONS

Dimensions in mm		MBR71
A	Overall Height	1300
B	Curb Clearance - Farside	215
C	Overhang - Farside	110
D	Drum Width	710
E	Overhang - Curbside	16
F	Curb Clearance - Curbside	410
G	Overall Length	2180
H	Drum Diameter	575
Drum Shell Thickness (not shown)		8.0

STANDARD / OPTIONAL EQUIPMENT

	MBR71
Gravity Fed Water System	Standard
Drum Scraper Bars Front and Rear	Standard
Operators' Proximity Switch	Standard
Low Maintenance Battery (12V)	Standard
Emergency Release Free Wheel Valve	Standard
Heavy Duty Central Lifting Point	Standard
Vandal Protection Package - Lockable Instrument Cover	Standard
Battery Isolator	Standard
Emergency Stop	Standard
Front Prop Stand	Standard
Rear Jockey Wheel	Standard
Electric Starting	Standard
Hour Meter	Standard
30 litres / minute hydraulic take-off valve	Standard
Stanley BR50 Vibro-Damped Hydraulic Breaker with tools, valve and hosing (light use only)	Option
Stanley BR67 Vibro-Damped Hydraulic Breaker with tools, valve and hosing (must be carried on towing vehicle)	Option
'Towit' Tow-Behind Trailer with Storage Box, Prop-Stand, Number Plate Lighting and Road Lighting	Option
Rear Prop Stand	N/A

SPECIFICATIONS COMPACT TANDEM ROLLERS

PERFORMANCE

	TV800	TV800H	TV900	TV1000	TV1200	TV1200H	TV1300	TV1400
Total Static Basic Weight (kg)	1446	1504	1455	2385	2740	2927	3240	4175
Operating Weight (kg) CECE	1559	1617	1568	2570	2925	3122	3435	4390
Static Linear load (kg/cm)	9.7	10.1	8.7	12.85	12.18	13.01	13.21	15.68
Frequency - Hz (VPM)	46/52 (2760/3120)			48/56 (2880/3360)				
Amplitude (mm)	0.5	0.5	0.5	0.5	0.6	0.6	0.5	0.5
Centrifugal Force (kN)	10/12.5	10/12.5	10/12.5	17/23	22/30	22/30	27/37	45/61
Gradeability (% - vibration on)	30	30	30	30	30	30	30	30
Gradeability (% - vibration off)	40	40	40	40	40	40	40	40
Drum Shell Thickness (mm)	10.0	10.0	10.0	10.0	10.0	10.0	10.0	10.0
Drum Finish	Machine chamfered edges							
Vibrating drums					Front and Rear or Rear Only (selectable)			

ENGINE & DRIVE

	TV800	TV800H	TV900	TV1000	TV1200	TV1200H	TV1300	TV1400
Engine Make	Kubota	Kubota	Kubota	Kubota	Kubota	Kubota	Kubota	Kubota
Engine Model	D905	D905	D905	D1703-M	D1703-M	D1703-M	V2203-M	V2203-M
Cylinders	3	3	3	3	3	3	4	4
Displacement (cc)	898	898	898	1647	1647	1647	2197	2197
Cooling	Water	Water	Water	Water	Water	Water	Water	Water
Power - kW (HP)	15.5 (20.8)	15.5 (20.8)	15.5 (20.8)	24.5 (32.83)	24.5 (32.83)	24.5 (32.83)	32.4 (43.4)	32.4 (43.4)
Operating Speed (rpm)	2500/3000	2500/3000	2500/3000	2300/2800	2300/2800	2300/2800	2300/2800	2300/2800
Fuel Type	Diesel	Diesel	Diesel	Diesel	Diesel	Diesel	Diesel	Diesel
Drive (both drums)	Hydrostatic	Hydrostatic	Hydrostatic	Hydrostatic	Hydrostatic	Hydrostatic	Hydrostatic	Hydrostatic
Travel Speed (kph)	8.0	8.0	8.0	8.0	10	10	10	10
Braking System - Service	Dynamic Hydrostatic (via propulsion system)							
Braking System - Parking	Spring Apply / Hydraulic Release on both drums							

TV800 TV1000 TV1300 TV800H TV1200 TV1400 TV900 TV1200H

WATERING SYSTEM

	TV800	TV800H	TV900	TV1000	TV1200	TV1200H	TV1300	TV1400
Tank Capacity (litres)	86	86	86	180	180	200	200	200
Spray Modes	Gravity / Pressure						Pressure	

ELECTRICAL SYSTEM

	TV800	TV800H	TV900	TV1000	TV1200	TV1200H	TV1300	TV1400
Battery (volts)	12V DC	12V DC	12V DC	12V DC	12V DC	12V DC	12V DC	12V DC
Alternator (amp)	30	30	30	55	55	55	55	55

LUBRICATION SYSTEM

	TV800	TV800H	TV900	TV1000	TV1200	TV1200H	TV1300	TV1400
Type	Grease - open loop, parallel circuit with centralised greasing points							

EMISSIONS

	TV800	TV800H	TV900	TV1000	TV1200	TV1200H	TV1300	TV1400
Engine	Euro Stage IIIA							
Noise (dBA)	106	106	106	106	106	106	106	106

SPECIFICATIONS **COMPACT TANDEM ROLLERS**

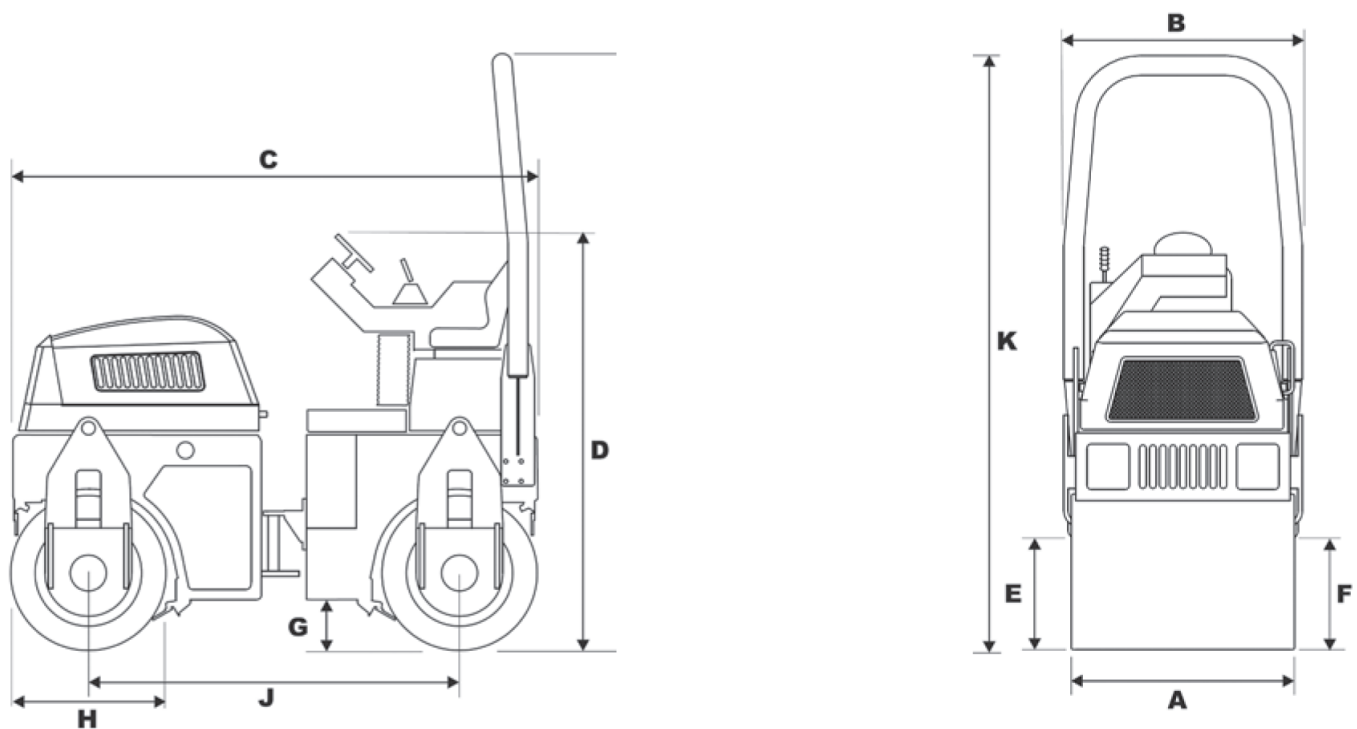

DIMENSIONS (mm)

	TV800	TV800H	TV900	TV1000	TV1200	TV1200H	TV1300	TV1400
A - Drum Width (mm)	800	800	900	1000	1200	1200	1300	1400
B - Overall Width (mm)	870	870	970	1070	1270	1270	1370	1470
C - Overall Length (mm)	1860	1860	1860	2375	2375	2375	2375	2375
D - Height to Top of Steering Wheel (mm - Transport Height)	1530	1530	1530	1940	1940	1940	1940	1945
E - Curb Clearance - Right (mm)	420	420	420	555	555	555	555	555
F - Curb Clearance - Left (mm)	390	390	390	490	490	490	490	490
G - Ground Clearance (mm)	200	200	200	230	230	230	230	230
H - Drum Diameter (mm)	550	550	550	700	700	700	700	706
J - Wheelbase (mm)	1260	1260	1260	1675	1675	1675	1675	1675
K - Height to Top of ROPS frame (mm)	2400	2400	2400	2650	2650	2650	2650	2655
Overhang - Left / Right (mm)	35/35	35/35	35/35	35/35	35/35	35/35	35/35	35/35

STEERING

	TV800	TV800H	TV900	TV1000	TV1200	TV1200H	TV1300	TV1400
Steering Type	Centrepoint Articulation - Double acting (via single hydraulic ram)							
Inside Turn Radius (mm)	1950	1950	1900	2625	2525	2525	2475	2425
Outside Turn Radius (mm)	2820	2820	2870	3695	3795	3795	3845	3895
Frame Articulation (degrees)	30	30	30	30	30	30	30	30
Frame Oscillation (degrees)	8	8	8	15	15	15	15	15

TV800 TV1000 TV1300 TV800H TV1200 TV1400 TV900 TV1200H

CAPACITIES

	TV800	TV800H	TV900	TV1000	TV1200	TV1200H	TV1300	TV1400
Hydraulic Tank Capacity (litres)	28	28	28	44	44	44	44	44
Fuel Tank Capacity (litres)	18	18	18	44	44	44	44	44
Water Tank Capacity (litres)	86	86	86	180	180	200	200	200

STANDARD EQUIPMENT

Fixed ROPS frame	Integral lifting points
Amber Beacon	Fuel and hydraulic oil tanks level gauges (TV1000 to TV1400)
Road Lights - UK Road Traffic Act compliant (TV1300 and TV1400 only)	Vandal Protection Package - Lockable instrument cover to deter vandals / thieves
Site Lights (Dependent on region)	Centralised greasing points for easy servicing
Gravity Fed Water System (TV800 to TV1200H only)	Vibration insulated operator's station
Pressurised Water System (TV1300 and TV1400 only)	Deluxe operator's seat with lap belt and traction cut-out switch - automatic stop if operator stands up during operation
Drum Scraper Bars Front and Rear (both drums)	
Articulation Lock Bar	Sliding operator seat (TV1200H to TV1400)
Removable plastic water and oil tanks for easy servicing	Fault finding lights on instrument panel
Low maintenance battery	Steering Knob
Single piece tilting engine hood	6 in 1 control lever
Emergency Release Free Wheel Valve (for Towing)	Hour meter

OPTIONAL EQUIPMENT

Folding ROPS frame	Audible Reversing Alarm
Road Lights - UK Road Traffic Act compliant (TV800 to TV1200H)	Sun Canopy (TV1000 to TV1400 only)
Pressurised Water Spray (TV800 to TV1200H)	Hydraulic Breaker attachment, tool, valve and hosing - 30 l/min (TV800 to TV900)

www.terex.com/construction

Effective Date: February 2014. Product specifications and prices are subject to change without notice or obligation. The photographs and/or drawings in this document are for illustrative purposes only. Refer to the appropriate Operator's Manual for instructions on the proper use of this equipment. Failure to follow the appropriate Operator's Manual when using our equipment or to otherwise act irresponsibly may result in serious injury or death. The only warranty applicable to our equipment is the standard written warranty applicable to the particular product and sale and Terex makes no other warranty, express or implied. Terex, the Terex Crown design and Works For You are trademarks of Terex Corporation or its subsidiaries. All rights are reserved. All other trademarks are property of their respective owners.
© 2014 Terex Construction.

Central Boulevard, ProLogis Park,
Coventry, England CV6 4BX
Tel +44 (0) 2476 339400



/TerexCorporation



@TerexCE



MyTerexConstruction



TEREX®

WORKS FOR YOU.™